



ENLARGING

WITH

**DE VERE**

**504 ENLARGER**

Models :- DVB / DVW / DVF / DVF Extd.

**Head Office:**  
DE VERE (Kensington) Ltd.,  
Vulcan Way,  
New Addington  
Croydon CR0 9UG  
☎ 0689 42222  
✉ 946252 Fax: 0689 41075

**Principal Factory & Foundry:**  
DE VERE (Kensington) Ltd.,  
Riverside Road,  
Pottington Industrial Estate,  
BARNSTAPLE, N. Devon,  
EX31 1NY, UK.  
☎ 0271-73273/6

**London Showroom:**  
DE VERE  
51/52 Friith Street,  
London W1V 5TE, UK  
☎ 01-434,4239

**Northern Showroom:**  
DE VERE  
Churchgate Chambers,  
48 & 48A Churchgate,  
STOCKPORT,  
Cheshire, SK1 1YG  
☎ 061-477 5520/1

**USA Office:**  
DE VERE (Sales) Inc.,  
Oakland Center,  
8980 Route 108, Columbia,  
Maryland 21045, USA.  
☎ (301) 596-3388  
✉ 4422011

**Canadian Office:**  
DE VERE (Sales) Canada Inc.,  
1093 Britannia Road E.,  
MISSISSAUGA,  
Ontario L4W 3XL  
☎ (416) 673-8711  
✉ 06-968764

# DE VERE 504 VERTICAL ENLARGER

## TABLE OF CONTENTS

DESCRIPTION	PAGE
Table of Contents	I - II
List of Illustrations	iii
<hr/>	
<b><u>Section One</u></b>	
Specification	1 - 1
120/240V Code Number Conversion Chart	1 - 4
<hr/>	
<b><u>Section Two</u></b>	
<b><u>Delivery and Unpacking</u></b>	
1. DVB & DVW	2 - 1
3. DVF & DVF Extended	2 - 2
<hr/>	
<b><u>Section Three</u></b>	
<b><u>Installation and Assembly</u></b>	
1. Assembly of 504 DVB	3 - 1
2. Assembly of 504 DVW	3 - 1
3. Assembly of 504 DVF & DVF Extended	3 - 1
4. Fixing to the Darkroom wall (DVW)	3 - 2
5. Installation of 504 DVB	3 - 2
6. Colour 500 Analyser	3 - 3
7. Electrical Connections	3 - 3
8. Fitting the Lightsource	3 - 3
Appendix 1. Electrical Connections	3 - 1 - 1
<hr/>	
<b><u>Section Four</u></b>	
<b><u>Guide to Controls and Major Components</u></b>	
1. Four Way Negative Masking	4 - 1
2. Negative Carrier	4 - 1
3. Dichromat Lightsource	4 - 2
4. Correction Tills	4 - 2
5. Negative Carrier Lift Pins	4 - 2
6. Lens and Negative Stage Adjusting Handwheels	4 - 3
7. Transformer/Stabilizer (TRANSTAB)	4 - 3
8. Universal Timer	4 - 3
9. Lens Panels	4 - 4
10. The Column	4 - 4
Appendix 1. Lens Panel Application	4 - 1 - 1
Appendix 2. Negative Carrier Combinations	4 - 2 - 1

---

## **Section Five**

### **Accessories**

1. Ancillary Components	5-1
2. Drop Table Assembly	5-1
3. Copy Adaptor (Copyback)	5-1
4. Lens Panel Extension Tube	5-1
5. Varicon (Black & White Head)	5-1
6. Varicon Pointsource Conversion Kit	5-2
7. Difcon	5-3
8. Cathomag	5-3
9. Varicon Contrast Head	5-3
10. 70mm Roll Film Drawer (Mark II)	5-3
11. Pin Register Carrier	5-4
Appendix 1. List of Ancillary Components	5-1-1
Appendix 2. Varicon Condenser Combinations	5-2-1

---

## **Section Six**

### **Maintenance, Replacements and Adjustments**

1.a. General Maintenance	6-1
b. Replacements	
(i) Dichromat Lamps (Mk 4)	6-1
(ii) Dichromat Lamps (Mk 5)	6-1
(iii) Display Panel Illumination Bulb (Dichromat)	6-2
(iv) Varicon Lightsource	6-2
(v) Cathomag	6-2
(vi) Drive Cable Replacement DVB/DVW	6-2
(vii) Drive Cable Replacement DVF/DVF Extd	6-4
c. Adjustments	
(i) Head Support Plate Nylon Tension Rollers	6-5
(ii) Drive Cable Tension	6-6
(iii) Drop Table Drive Chains	6-7
(iv) Lens and Negative Stage Tilt Mechanisms	6-7
(v) Tensioning Negative and Lens Stage Handwheels	6-7
(vi) Lens Panel Retaining Bosses	6-8

---

### **Attachments**

#### **Spare Parts List**

Edition 1 - Jan 84  
2 - Dec 84

## 504 ILLUSTRATIONS

Figure No	Description	Section-Appx-Page
1	504 Vertical Enlarger	1 - 3
2	Column to Base Casting	3 - 1
3	Column to Drop Table	3 - 1
4	Fitting Timer Trays	3 - 2
5	Fixing to the Darkroom Wall	3 - 2
6	Fitting the Lightsource	3 - 3
7	Electrical Connections	3 - 1 - 1
8	Four Way Masking	4 - 1
9	Universal Timer	4 - 3
10.	Lens Panel Application	4 - 1 - 1
11.	Negative Carrier Combinations	4 - 2 - 1
12.	Roll Film Drawer	5 - 3
13.	Pin Register Location Plate	5 - 4
14.	Pin Register Carrier	5 - 4
15.	Varicon Condenser Combinations	5 - 2 - 1
16.	Cable Routing & Securing Points DVB/DVW	6 - 3
17.	Cable Attachment to Drive Pulleys DVB/DVW	6 - 3
18.	Cable Attachment to Drive Pulleys DVF/DVF Ext	6 - 4
19.	Cable Routing & Securing Points DVF/DVF Ext	6 - 5
20.	Adjustment of Tension Rollers	6 - 5
21.	Lightsource & Negative Stage Gap	6 - 6
22.	Drive Cable Adjustment	6 - 6
23.	Lens Panel Retaining Bosses Adjustment	6 - 6

## SECTION ONE

### SPECIFICATION

The De Vere 504 Enlarger is designed for both colour and black and white printing with readily interchangeable lightsources. It will accept negative formats up to and including 4in x 5in (10cm x 12.5cm) and embodies both rigidity of design and excellent operational reliability. Currently four versions of the 504 are available, these are:

- a. Model DVB
    - A Bench mounted machine with the front of table controls and a 24in x 24in (61cm x 61cm) baseboard fitted.
  - b. Model DVW
    - A wall mounted machine with Base level controls. A drop table is available as an extra which will then enable prints up to and including 32in x 42in (81cm x 107cm) to be made.
  - c. Model DVF
    - A free standing machine with adjustable table and front of bench controls allowing prints up to 32in x 42in (81cm x 107cm) to be made.
  - d. Model DVF ExLnd
    - Basically the same as the DVF Model but has a 16in (406mm) longer column and a 62in x 42in (157.5cm x 107cm) baseboard fitted.
- Colour 500 Analyser
  - The De Vere Colour 500 Analyser is a factory fitted extra available with the Colour Enlarger. This analyser features completely automatic exposure, digital readout, magnification scale and programmable plug-in modules.
- Colour Head
  - Dichromat A diffused, dial in dichroic colour head with stepless fade free filtration calibrated between 0 - 200. Two versions are available:
    - (i) Mark 4: using one 24 volt constant colour temperature tungsten halogen lamp giving 250 watts of light output.
    - (ii) Mark 5: using two of the 24 volt constant colour temperature tungsten halogen lamps used in the Mark 4, therefore giving twice the light output, 500 watts complete with shutter.
- Various lightboxes to concentrate the output are available if required for both lightsources.

Black & White Head

- Varicon A variable condenser head employing a 150 watt tungsten lamp with matched optical condenser lenses to give optimum coverage which can be easily exchanged in a drawer above the negative stage. Facilities are included for the use of heat suppression filters or gelatine colour printing filters if required.

Difcon A diffused tungsten source of high intensity giving the same light output as the Mark 5 Dichromat, enabling short exposures on small format black and white negatives to be made.

Cathomag A high power diffused lightsource employing a special cold cathode grid. Lenses of any focal length may be used without adjustment to the system. This source suppresses dust and blemishes normally visible on prints made with a condenser system.

Pointsource A variable pointsource light is available in the form of a Conversion Kit for the Varicon Head.

Varicontrast Head A lightsource that has been specifically developed for use with both Polycontrast and Multigrade papers. A diffused tungsten lightsource that returns a high print quality.

Enlarger Lens Range

- All lenses from 25mm to 150mm.

Negative Carrier

- Sandwich type either glass or glassless.

Controls

- Manually operated front of baseboard controls for both Lens and Negative Stage. (Base level controls for the DVW)

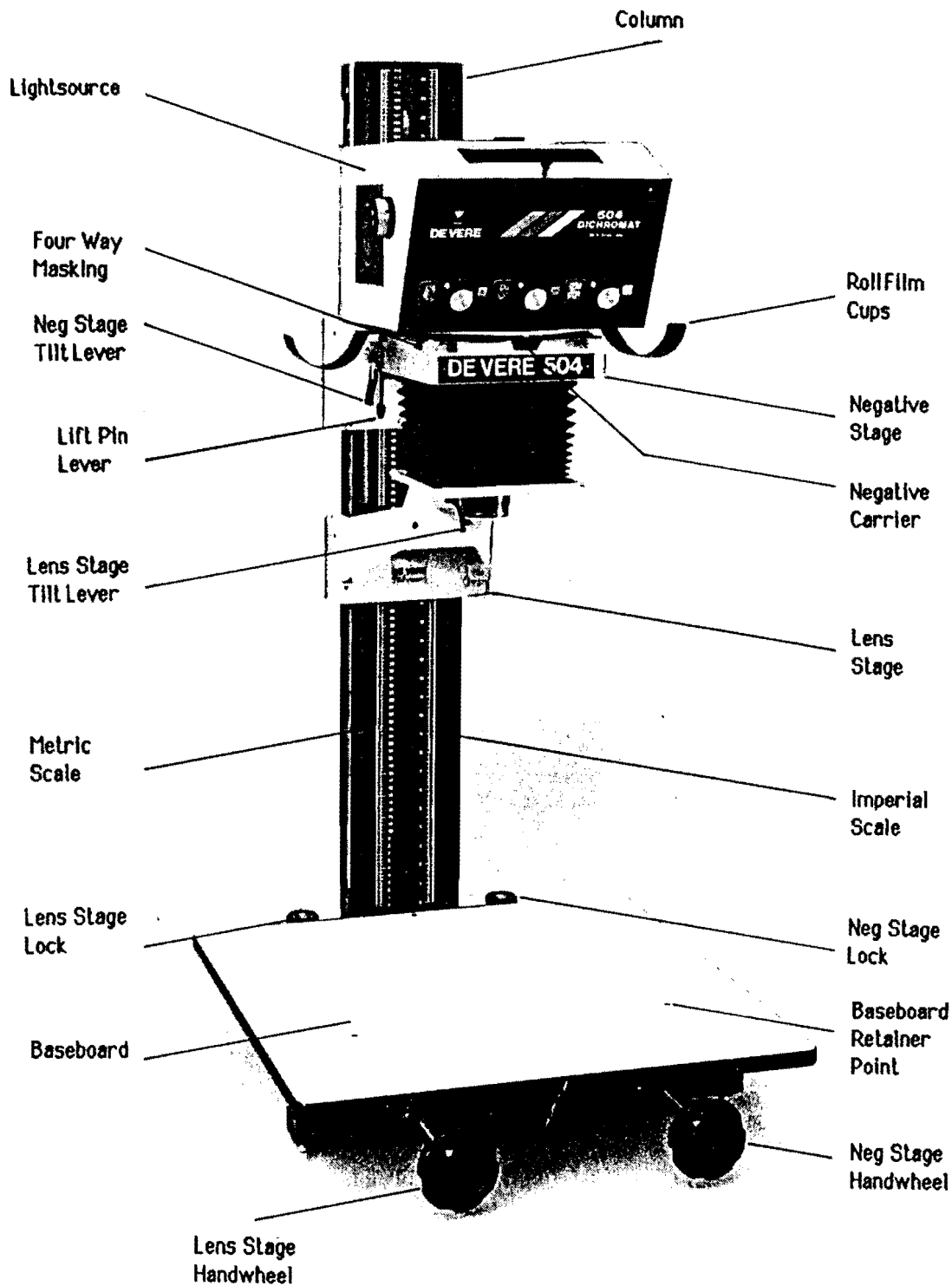
Accessories

- A wide range is available, see Section Five.

Power Requirements

- Either 210/240 Volts 6 amps 50HZ AC or 110/120 Volts 12 amps 60 HZ AC.

# DE VERE 504 VERTICAL ENLARGER



Model shown: 504 DVB with Dichromat Colour Head fitted.

Fig 1.

**240/120 Volt Converter for the De Vere 504 Enlarger**

Code Number		DESCRIPTION
240V	120V	
1984	1991	Dichromat Mk 5 500 Watt Colour Head
1983	1992	Dichromat Mk 4 250 Watt Colour Head
1993	1994	Difcon Mk 2 500 Watt Black & Watt Head
1962	1995	Transtab 250 Watt
2619	2636	Transtab 500 Watt
1903	1996	Transformer 250 Watt
2620	2637	Transformer 500 Watt
1961	1999	Timer/Transtab 250 Watt
2618	2638	Timer/Transtab 500 Watt
1905	Specify	Cathomag (requires Code 2902 for 120V version)
1906	Specify	Varicon
6603	Specify	Colour 500 Mk 3 c/w DVB 504 Chassis
6604	Specify	Colour 500 Mk 3 c/w DVW 504 Chassis
6605	Specify	Colour 500 Mk 3 c/w DVF 504 Chassis
6606	Specify	Colour 500 Mk 3 c/w DVF Extnd 504 Chassis
--	3845	120V Timer interface to Transtab or Transformer. Connects to 8 pin multi-plug and accepts Timers with US type plugs.

Specify - Use the Code Number for 240V but specify for use with a 120V system when ordering.

		ACCESSORIES
1860	1861	RE 6 Roll Paper Easel 16in x 20in
1850	1851	RE 5 Roll Paper Easel 12in x 17in
3838	3839	Roll Paper Easel to Colour 500 Interface
3841	3841	Roll Paper Easel Lamp Detector Interface

**Note:**

All Code Numbers used in this Manual are, where applicable, for 240V components. This converter has been included in the manual to assist those with 120V machines.



## SECTION TWO

### DELIVERY AND UNPACKING INSTRUCTIONS

#### DVB (Code 1980) & DVW (Code 1982)

##### 1. Delivery

The De Vere 504 Enlarger will normally be delivered in component form securely packaged within a specially designed carton which will contain:

- a. The Main Column.
- b. The Base Casting (DVB Model only).
- c. The Baseboard (DVB Model only).
- d. Two wall mounting brackets complete with all fixings (DVW Model only).
- e. Two handwheel control rods.
- f. A lightsource.
- g. Any other accessories.

##### 2. Unpacking

To avoid any accidental damage to components, they should be unpacked in the following order:-

- a. Lay the carton on the floor and gain access through the divided panel.
- b. Remove the two handwheel control rods located through holes in the central vertical partition. Then remove the central partition that supported them.
- c. Remove the carton containing the lightsource and accessories.
- d. Remove the base casting and baseboard (DVB Model only).
- e. Remove the packing that supports the lens runner assembly and lift the complete column from the packing case.
- f. Place onto a flat work surface with the front face uppermost and remove all protective wrapping.
- g. IMPORTANT A piece of wood will be seen wedged between the head stage runner and a slot in the top of the column. This must not be removed until the lightsource is fitted otherwise damage to the column will result. Instructions for its removal are contained in Section 3.

##### NOTE:

Examine all components for damage and ensure that those delivered agree with those listed on the delivery documents. Any claims for either damage or shortages must be made within seven days of receipt of the equipment.

DVF (Code 1981) & DVF Extnd (Code 1998)

3. Delivery

The DVF and DVF Extended Models, like the DVB and DVW, will normally be delivered in component form securely packaged within a specially designed crate which will contain:

- a. The Main Column with runners attached.
- b. Drop Table Assembly.
- c. Baseboard.
- d. Lightsource and Accessories.
- e. Timer Tray.
- f. All Fixtures and Allen Keys required.

4. Unpacking

The crate in which the 504 DVF/DVF Extnd is contained, has been designed for use with a fork lift truck, so should be positioned as near as possible to the operating position prior to opening.

- a. Gain entry to the crate through the panel indicated 'OPEN'.
- b. Remove the central support bar.
- c. Release the retaining battens and remove all cartons containing accessories.
- d. Remove the two securing battens and the two screws in the floor retaining the Drop Table. In the case of the DVF Extnd Model the Drop Table Support Legs will be attached.
- e. With one hand, support the column assembly while extracting the Drop Table with the other.
- f. Remove the Column Assembly.
- g. Remove the battens securing the baseboard and Timer Tray then remove both assemblies.
- h. Remove all wrapping and packing materials from the assemblies.
- j. IMPORTANT: A piece of wood will be seen wedged between the head stage runner and a slot in the top of the column. This must not be removed until the lightsource is fitted otherwise damage to the column will result. Instructions for its removal are contained in Section 3.

NOTE: Examine all components for damage and ensure that those delivered agree with those listed on the delivery documents. Any claims for either damage or shortages must be made within seven days of receipt of the equipment.

## SECTION THREE

### INSTALLATION AND ASSEMBLY

#### 1. Assembly of 504 DVB

- a. With the column already on the work surface, front uppermost, take the base casting and engage the rectangular slot with the spigot at the bottom of the column.
- b. Insert the two socket headed retaining screws through the clearance holes in the base then, by slightly moving the base either one way or the other, locate the screws into the threaded holes in the column. Fully tighten these screws with the Allen Key provided then raise the assembly to the vertical position.
- c. Remove the socket headed screws fitted into the ends of the control rods, insert the rods through their respective support holes at the front of the base and into the tapered holes at the base of the column. Holding the control handwheel with one hand, tighten both screws fully with the AllenKey provided. This operation will lock the control rods into the drive mechanism.

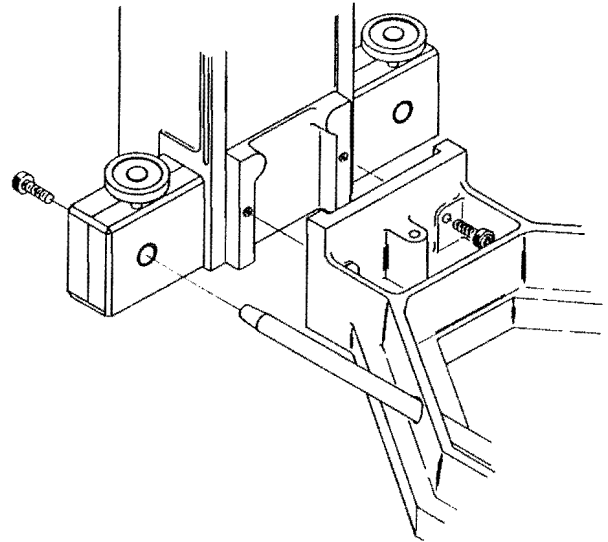


Fig 2

- d. Place the baseboard, countersunk holes uppermost, onto the three levelling points on the base casting, then line up the front left hand screw hole with the levelling point into which the retaining screw is fastened. The three countersunk screws required to hold the baseboard are located in the plastic bag along with the allenkeys, this is taped to the base casting. Insert the screw and tighten just a few turns, therefore leaving it loose at this stage. Repeat this operation with the front right and the rear securing screws and then fully tighten all three screws with the AllenKey provided. The three levelling points have been factory set so should not be adjusted in any way.

#### 2. Assembly of the 504 DVW

The assembly procedure for this model is the same as for para 1. c. above.

#### 3. Assembly of 504 DVF & DVF Extnd

- a. Place the Drop Table assembly on the floor as close as possible to the position where the enlarger is to be used.
- b. Remove the two bolts securing the wooden blocks on the Drop Table, discard the blocks but retain the bolts and washers.
- c. Place the column base onto the Drop Table and secure with the two allen cap screws provided.

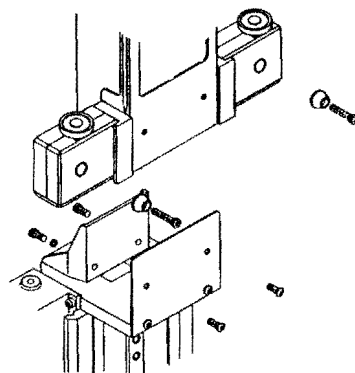


Fig 3.

- d. The two bolts and washers removed from the wooden blocks should now be relocated into their holes through the base of the column.
- e. The two transit screws at the upper rear of the chain guard may now be fully released.
- f. Locate and secure the Timer Tray with the bolt and spacers provided.
- g. Attach the wall securing bracket to the top of the column.
- h. Fit and secure the baseboard with the wing nuts supplied.

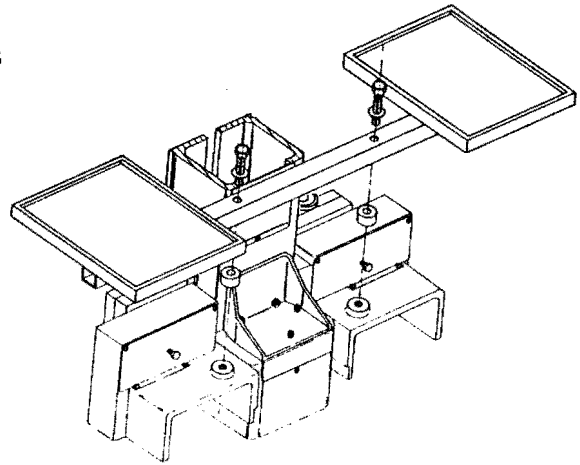


Fig 4.

#### 4. Fixing to the Darkroom Wall (504 DVW)

The DVW Model is supplied complete with all fixtures required to attach the enlarger to the operating wall less the two wooden battens. Before fixing the enlarger onto the wall however, consideration should be given to the power supply availability and the operating height required. Once a position has been decided upon proceed as follows:

- a. Affix two 4in x 1in x 18in (10cm x 2.5cm x 46cm) wooden battens horizontally onto the wall at 48in (122cm) vertical centres. See the Diagram below. Ensure the two battens are both level and parallel and that they are securely attached to the wall so that a total weight of approx 39kg. (85lbs) can be safely supported.
- b. Position one wall bracket against the top batten approximately 4in (102cm) from the end and mark the position of the bracket screw holes onto the batten. Ensure the bracket is level before marking.
- c. Fit and secure the four brackets to the enlarger column using the bolts provided as shown opposite.
- d. With the help of another person position the enlarger against the battens and secure the top bracket to the batten.
- e. Slacken the bolts in the slotted holes of the bracket, then adjust the position of the enlarger until it is both vertically and horizontally level, then tighten all screws.
- f. Secure the bottom bracket to the batten and double check that all screws are fully tightened.
- g. Finally, check the horizontal and vertical levels and adjust if required.

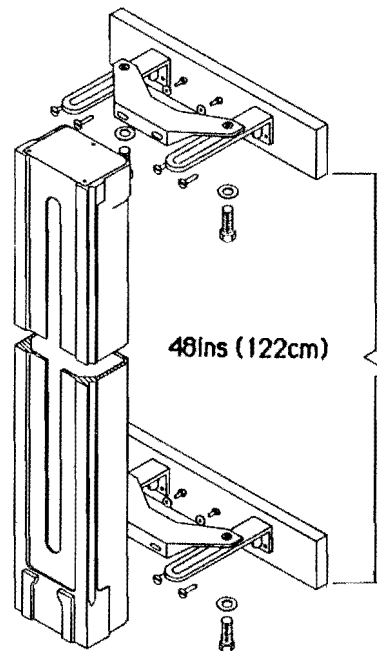


Fig 5.

**NOTE:** As advised in Section 2, do not remove the wooden wedge at the top of the column until the light source has been fitted.

#### 5. Installation of 504 DVB

- a. The DVB Model once located onto the firm and level work bench will not, under normal operating conditions, require securing. Should however, this be considered necessary, two countersunk holes are provided in the base casting for this purpose.
- b. Any levelling of the enlarger can be done by turning the four dome head adjusters located on the underside of the base casting.

## 6. Colour 500 Analyser

When fitting a Colour 500 Analyser, reference should be made to the separate manual supplied for both fitting and full operating instructions.

## 7. Electrical Connections

A detailed chart showing the connections of all electrical components is at Appendix 1 to this Section.

- a. Ensure the enlarger electrical components are compatible to the mains power supply to be used. A small plate or label will be attached to each component giving the voltage, serial number etc., and will normally be attached to the underside or rear of the component.
- b. When a Timer is not being used in conjunction with the Transtab, the shorting plug supplied with the Transtab must remain fitted for operation to be possible, as shown in the diagram at Appendix 1 to this Section.

## 8. Fitting the Lightsource

All types of lightsources available for the 504 series of enlargers are fully interchangeable, the method of mounting and attachment to the enlarger being common to all.

- a. Ensure that both Lens and Negative Stage runner locking knobs are firmly locked. This is essential to avoid uncontrolled upward movement of the runners and possible damage to the equipment.
- b. Release the left hand locking knob and wind the Lens Stage runner down as far as it will go using the left hand control wheel then re-lock.
- c. Using one hand to support the Negative Stage runner, therefore preventing rapid upward movement, release the right hand drive locking knob and bring the negative stage down to a convenient working height then tighten the locking knob securely. Remove the wooden wedge from the top of the column. Repeat if necessary to obtain a convenient working height.

- d. Remove the transit tape retaining the lift pins and lightsource tension spring in position on the negative stage.

- e. Lift the lightsource and position so that the two rollers on the hanger casting at the rear of the lightsource housing enter the cast V' shaped recesses in the rear of the Negative stage runner back plate.

- f. Connect the tension spring to the rear panel of the lightsource by placing the upper hole in the metal tag over the head of the screw provided. This prevents movement of the lightsource on the stage as it is raised and lowered on the column.

- g. Attach the lightsource cable to the cable clip located on the rear of the column.

- h. The four nylon rollers located within the Negative Stage back plate are levelling rollers for squarely seating the lightsource when in position. These are factory adjusted and will not require attention unless the lightsource is continually being fitted and removed. The method of adjustment is fully explained in Section 6.

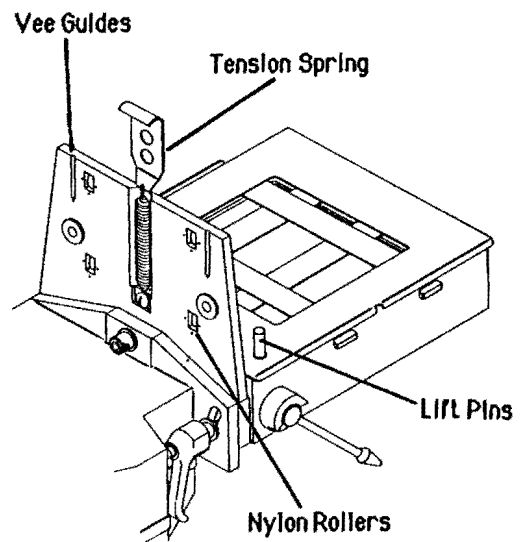
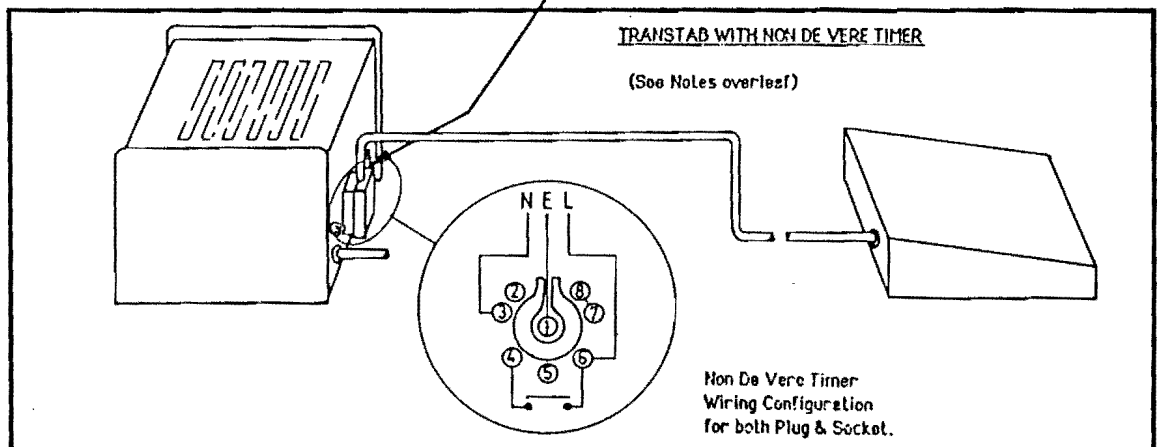
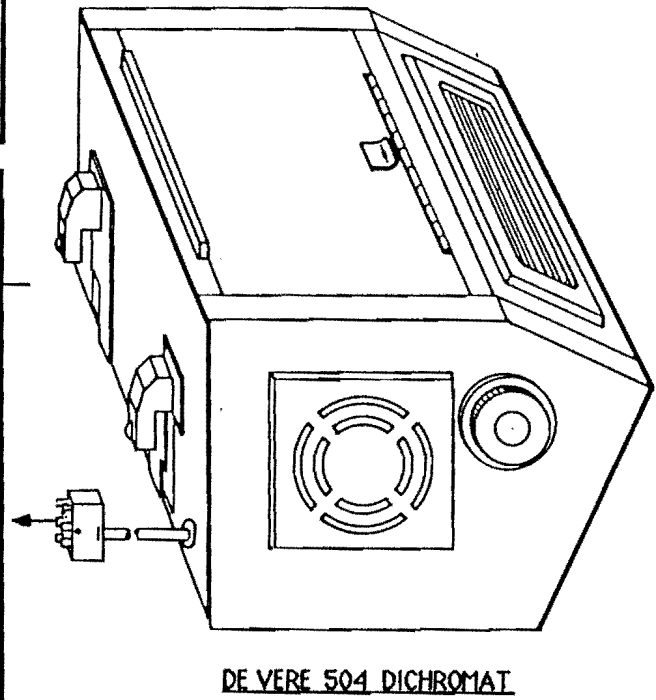
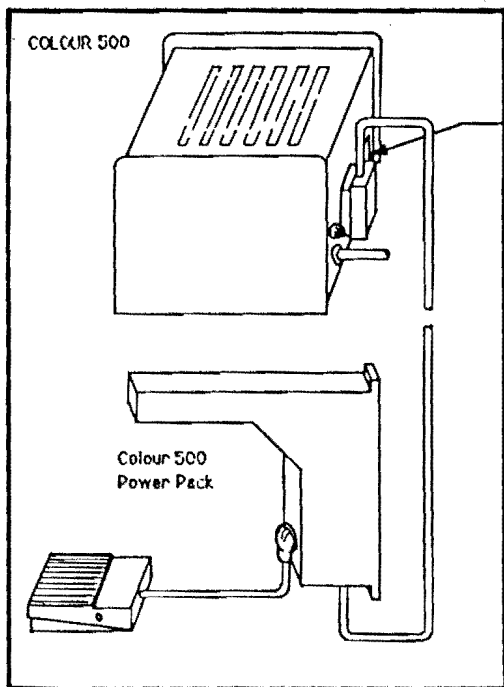
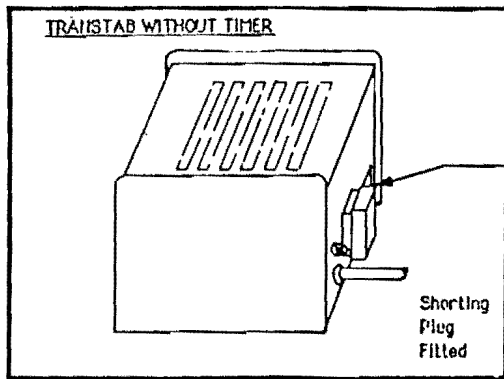
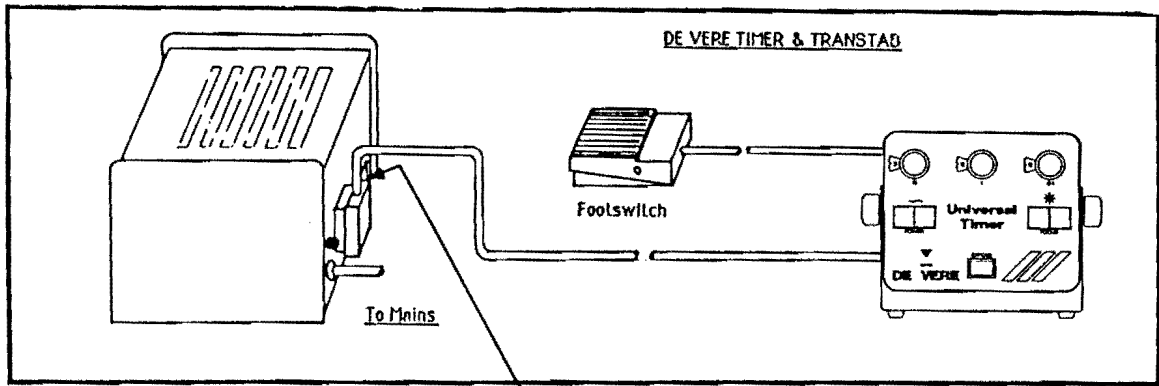


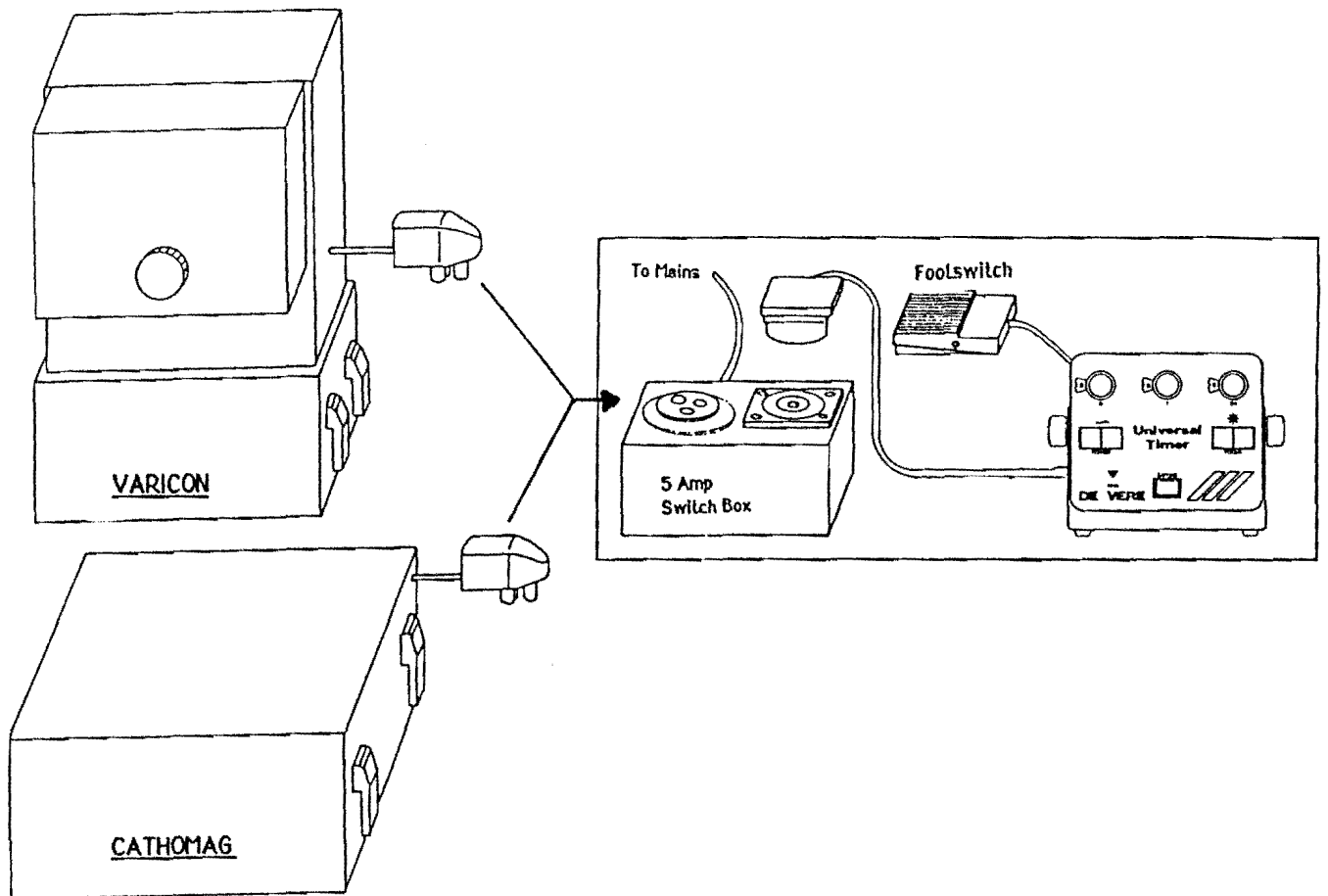
Fig 6.

**ELECTRICAL CONNECTIONS**



**NOTES:-**

- a. Plug should be inserted with terminals 7 & 8 joined to effect a shorting plug.
- b. The switch connections should be made between terminals 4 & 6, [REDACTED] with the Earth connected to Terminal 1.
- c. Advice on the wiring in of other than De Vere Timers can be given on request.



## SECTION FOUR

### GUIDE TO CONTROLS AND MAJOR COMPONENTS

#### 1. Four Way Negative Masking

The Four Way Negative Masking facility is located within the Negative Stage and comprises four independently adjustable masking blades, the outer ends of which protrude from the Negative Stage and are capped with black plastic handles as shown in the diagram below. Infinite adjustment of the blades is possible by sliding them and positioning wherever required.

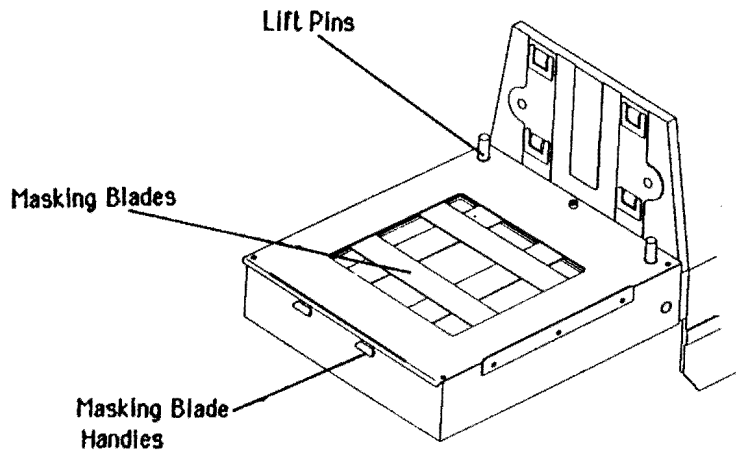


Fig 8.

#### 2. Negative Carrier

The hinged Sandwich Negative Carrier System accepts a range of glassless interchangeable film masks or a pair of standard glasses. Anti Newton glass is available for use with the standard glasses if so required. Special Negative Carriers can be supplied on request for unusual size negatives, but a complete list of the masks and glasses available is at Appendix 2 to Section 4. The carrier has a spring loaded pop-up catch that works in conjunction with the lift pins (See para 5). Raising and lowering the lightsource onto the Negative Carrier closes the carrier and presses the film flat. When the pins are raised the carrier 'pop-up' catch opens the carrier, allowing the roll film to be fed through to the next frame without scratching the negative. A pair of rollfilm cups, which clip into slots on the side of the carrier to support long lengths of rollfilm can be supplied as an extra. To load the carrier with a length of film, proceed as follows:

- a. Fit a pair of film masks of the correct aperture for the film size being used into the carrier, ensure the mask with the location pins, is attached to the bottom face of the carrier, pins facing upwards, and the mask with the holes, is attached to the top face. Ensure that both masks are correctly seated and clipped into position.
- b. Fit the RollFilm cups into the slots on the side of the carrier if these are to be used.
- c. Pass the film between the location pins then bring both halves of the carrier together.



### 3. Dichromat Lightsource

The 504 Dichromat may be supplied in two forms, the Mark 4 is a single lamp 250 watt unit and the Mark 5, a twin lamp 500 watt unit.

- a. The standard lightbox, measuring 5ins x 5ins (127mm x 127mm) fits into the upper rear compartment of the Dichromat but, an interchangeable 2.1ins x 2.4ins (6mm x 7mm) lightbox may be supplied for use with smaller formats for both the Mark 4 and Mark 5 models. These lightboxes for the two models differ in that the Mark 4 has just one lamp aperture and the Mark 5 has two; they are therefore not interchangeable.
- b. The three filter adjusting knobs, Cyan, Magenta and Yellow complete with setting dials are located on the front panel of the lightsource and indicate a filtration range that is calibrated between 0 - 200.
- c. A separate white light control knob located on the left hand side of the Dichromat next to the air intake, will, when turned fully in an anti-clockwise direction away from the operator, remove all the filters from the light path and so provide a white light for focussing purposes. The operation of this control, whether to remove or return the filters to the light path, will not affect any filter values that may have been pre-set.
- d. In order to indicate that this white light facility is in use, a white 'tell tale' light beam has been incorporated into the white light control knob so that when the knob has been turned fully in an anti-clockwise direction, thus removing the filters from the light path, a beam of white light will show in a forward direction towards the operator.
- e. The panel lights are controlled by the switch located on the upper right of the front panel. The operation of this switch will only control the illumination of the Filter Setting Dials and will not affect the operation of the main lightsource or the white light indicator.
- f. Both models of the 504 Dichromat are cooled by integral rubber mounted vibration free fans.
- g. In the event of a lamp failure, detailed instructions for the access to and the checking and replacement of defective lamps are contained in Section Six.

### 4. Correction Tilts

All models of the 504 have a correction tilt facility fitted to both the negative and lens stages. Click stops are also fitted to both stages to ensure the positive return to the central, level, operating position. Each of the two stages has its own locking lever, on the lens stage this is located in the centre of the casting on the front face, and on the negative stage, it is situated on the left hand side of the runner casting immediately behind the lift pins operating lever.

- a. To tilt either of the stages, release the locking lever by rotating in an anti-clockwise direction. Adjust the degree of tilt required then re-apply the locking lever.
- b. Both locking levers are keyed to their shafts by splines and if, for ease of operation, it is required to change their positions, release the lock, pull the lever away from its shaft then re-engage the splines into the desired position.

### 5. Negative Carrier Lift Pins

The location of the two lift pins is shown in the Diagram at paragraph 1 to this Section. These two pins, that protrude from the negative stage casting, are operated by the long lever on the left hand side of the negative stage. By pushing this lever, therefore raising the pins, the complete lightsource is raised allowing the Negative carrier to be inserted into position. By pulling the lever back towards the front of the enlarger the pins will retract therefore allowing the lightsource to lower onto the carrier retaining it firmly in position.

## 6. Lens and Negative Stage Adjusting Wheels

The two large black handwheels situated at the front of the enlarger control the movement of the lens and Negative Stages, the left handwheel controls the lens stage and the right hand one the Negative stage. At either side of the base of the column are the two locking knobs for each of these handwheels. It is most important that both these are in the locked position whenever movement of the two stages is not taking place and in particular when changing light sources. These conveniently situated handwheels are positioned to aid operation and in particular make focussing easier than on conventional enlargers. It is recommended that a focussing aid be used for the best results and these are available from De Vere.

## 7. Transformer/Stabilizer (TRANSTAB)

The De Vere 504 TRANSTAB Control Box has two switches marked 'Mains' and 'Focus' located on the front panel. The 'Mains' switch should always be in the 'On' position when the enlarger is in use, therefore providing the mains electrical current to the TRANSTAB. The 'Focus' switch, when in the 'On' position, will bring the light source into operation, this switch should remain switched off when used with the Electronic Timer or in conjunction with the Colour 500 Analyser. A detailed wiring instruction chart showing all wiring connections is appended to Section Three. Two versions of the 504 TRANSTAB are available, the 250 watt, for use with the single lamp Mark 4 Dichromat and the 500 Watt, for use with the twin lamp Mark 5 Dichromat.

### a. Fuse Replacement

Special Anti Surge fuses are used in this component and spares, when required, should be requested from your De Vere local agent.

## 8. Universal Timer (Not required with Colour 500 Analyser)

The layout of the Universal Timer Control Panel is shown in the diagram below. At the top of the panel are three black knobs each with a dial, marked 0.1, 1 and 10 seconds, and graduated from 0 - 9 in 0.1 secs, 1 secs and 10 secs respectively, therefore allowing a maximum exposure time of 99.9 secs to be pre-set. The timer is a free standing unit and a facility has been included to allow the Control Panel to be tilted for ease of operation. The black knobs on both sides of the unit can be released and lightened to effect this tilt. Located on the lower portion of the control panel are three switches, these are:

### a. Power

This provides power for the Timer and must be switched on whenever the Timer is in use.

### b. Focus

When in the On position provides a constant light from the light source with which to focus. When the focussing has been completed return the switch to the Off position.

### c. Expose

A momentary switch, that when pressed, will initiate the complete exposure sequence switching the light source on for the period set on the electronic timer.

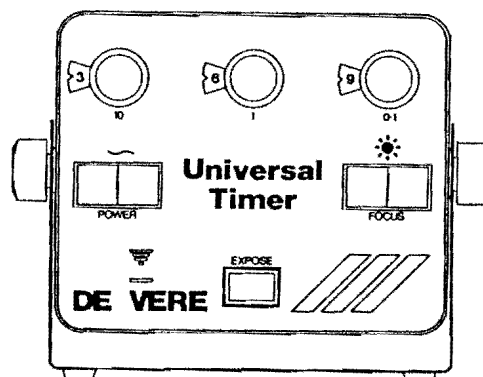


Fig 9.

## 9. Lens Panels

To cover the normal range of lenses for the 504, three types of lens mounting panel are required. The application of each of these panels is shown in the table at Appendix 1 to this Section. The lens panels attach to the lens stage with a bayonet type connector. The two plastic coated bosses, which are recessed into the stage, occasionally require minor adjustment when panels are continually being connected or disconnected, instructions for this adjustment are contained in Section Six.

## 10. The Column

The Column has been manufactured from the highest grade aluminium to ensure rigidity for the life of the enlarger. On the forward face of the Column are both Imperial and Metric scales to aid rapid re-positioning of the lens and negative stages. Stainless steel V guides attached to the column ensure many years of very precise operation of both Stages.

**LENS PANEL APPLICATION CHART**  
**DE VERE 504 VERTICAL ENLARGER**

Standard  
 Lens Panel  
 Order Code

LENS FOCAL LENGTH (MM)															
28	35	50	60	75	80	90	105	135	150	180	210	240	300	360	
1922		1920		1921											

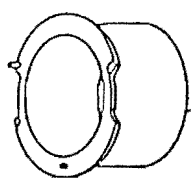
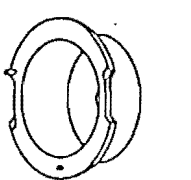
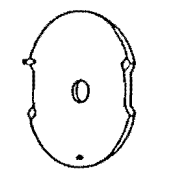
Standard Order Code and Description	Diagramatic View of Standard Panel	Order Code for Lieca Thread
<u>1922</u> Series 500 Extra Sunken Panel		1977
<u>1920</u> Series 500 Dished Panel		1972
<u>1921</u> Series 500 Flat Panel		1973

Fig 10.

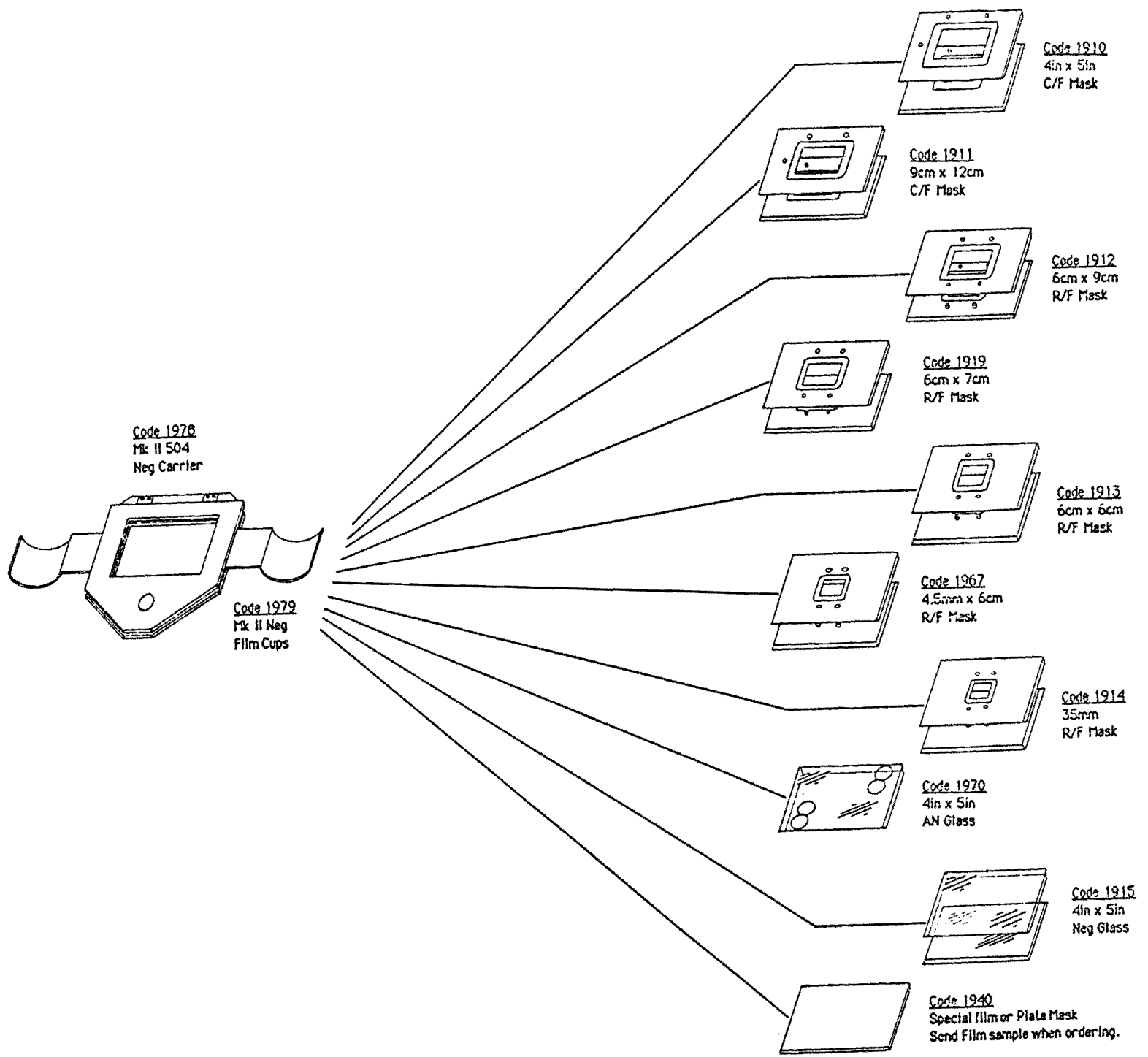


Fig. 11.

**NEGATIVE CARRIER COMBINATIONS**

Appendix 2 to Section Four

## SECTION FIVE

### ACCESSORIES

1. A complete list of Ancillary Components and Accessories for the 504 is at Appendix 1 to this Section but the following paragraphs outline the operation of the more common used items.

2. Drop Table Assembly (Code 1939)

This assembly is designed for use with the wall mounted DVW Model and provides an adjustable rise and fall table (baseboard) which when fully extended will enable prints up to and including 32in x 42in (81cm x 107cm) to be produced. This accessory, in effect, offers a budget priced DVF Model without the front of baseboard controls.

- a. This assembly comprises a cast column with a runner similar to the main enlarger column with a square steel tubular framework attached to the runner to support the table. Counterbalance springs make the vertical rise and fall adjustment of the table assembly both easy and light.
- b. The complete assembly connects to the base of the enlarger and the provision of an adaptor plate ensures the correct positioning in relation to the enlarger column.
- c. Dome headed levelling adjusters are provided on the underside of the base casting and holes to accommodate retaining screws to secure the complete assembly to the floor are provided should this be considered necessary. It is recommended that the top of the column is attached to the wall with one of the brackets supplied with the DVW Model enlarger.
- d. The height of the table may be adjusted by the central lever located just below the front of the table. A number of conveniently located stops are provided for speed of operation.
- e. A Diagram, Fig 3, showing the connection points between the table and the column, is in Section Three.

3. Copy Adaptor (Copyback X Code 1907)

All Models of the 504 enlarger can be used as a Copy Camera and are quickly converted to this role by means of the copyback adaptor and a springback universal slide holder that allows artwork or transparencies to be photographed onto 4in x 5in sheet or roll film. Attachment of the adaptor to the Negative Stage, in place of the light source, is by two retaining clamps that secure to the underside of the Negative Stage casting. The hinged viewing mirror allows focussing through the ground glass screen to be undertaken easily. The springback may be used for both landscape or portrait prints. The counter-balance weight supplied with the Copyback must be positioned behind the head support plate and the pin on the weight located into the hole provided.

4. Lens Panel Extension Tube (Code 1923)

Should special reductions be required, a lens panel extension tube which has bayonet connections at both ends may be supplied to increase the effective extension of the bellows from 19in (483mm) up to 22.25in (565mm).

5. Varicon (Black & White Head X Code 1906)

A quality interchangeable variable condenser system for use with formats up to 4in x 5in (102mm x 127mm) that uses a single 150 watt 240 volt bulb. The light source is cooled by convection and great care should be taken not to cover the louvres provided for this cooling.

- a. Adjustment of the light evenness may be made by turning the knob located on the side of the lamphouse, which will move the bulb up and down within the housing.
- b. Immediately below the lamphouse is a drawer to accommodate 16cm square gelatine C.P. filters should these be required.

- c. A 14cm heat filter (Order Code 1944) may be inserted into the head assembly by removing the four knurled headed screws situated two on each side of the unit, and then removing the upper section of the head assembly. The seating position for the heat filter will now be both visible and accessible.
- d. Immediately above the negative stage is the condenser compartment, the door of which is retained in position by a magnetic catch. The condenser elements are located on slideways within this compartment therefore making interchangeability both easy and quick. Always place the lower element into the housing first with the convex surface facing upwards, away from the lens stage.
- e. The table at Appendix 2 to this Section shows the condenser element combinations and the focal lengths of the enlarging lenses which may be used.
- f. To operate the Varicon proceed as follows:
  - (i) Connect the main power supply then switch on at the Transtab and the Timer if used.
  - (ii) Press the Focus switch on the Transtab or Timer if used; the lightsource will now be on.
  - (iii) Size and Focus a Negative.
  - (iv) Remove the Negative from the Carrier then move the bulb up and down within the housing until optimum evenness of light is gained.
  - (v) Replace the Negative and proceed with the exposure sequence.
- g. In the event of a bulb failure, instructions for changing are contained in Section Six.

#### 6. Varicon Pointsource Conversion Kit (Code 1950)

- a. The standard Varicon lightsource can be converted to Pointsource operation with this conversion kit which is supplied complete with a variable light dimmer control unit. The change is effected by removing the lightsource portion of the Varicon which is secured by four knurled knobs and then replacing with the Pointsource lamphouse.
- b. Connect the lead for the lamphouse into the Dimmer Control Unit and the lead from the Dimmer Unit to either the mains direct, or to a Universal Timer Interface and then into the main power supply; see Appendix 1 to Section 3.
- c. The 46 watt 6 volt point lamp contained within the lamphouse may be positioned by the adjusters on the top of the unit with the light intensity being adjusted with the variable dimmer control unit.
- d. Adjustment of the lightsource should be carried out as follows:
  - (i) Project a white light image onto the baseboard.
  - (ii) Close the diaphragm of the lens, this will induce fringing of the image.
  - (iii) Adjust the two knurled headed screws on the top of the lamphouse until the circular image with fringing is centralised.
  - (iv) Fully open the diaphragm of the lens, then pull or push the central adjusting rod until apparent evenness of the image light has been obtained.
  - (v) Adjust the light intensity with the Dimmer Control for the appropriate exposure.

7. Difcon (Code 1993)

The Difcon black and white lightsource has the same light output and quality as the Dichromat Mark 5 described in Section Four. Operation is also the same but being a black and white lightsource, no colour filters are fitted. Detailed fitting instructions are contained in Section Three, the unit being the same as the Dichromat.

8. Cathomag (Code 1905)

- a. The Cathomag Lightsource is designed solely for black and white printing. It has a high power diffused lightsource which suppresses dust and negative blemishes normally visible on a print produced with a condenser lightsource.
- b. Printing speeds are compatible and normally a one grade harder printing paper will be necessary to obtain a satisfactory quality print with an increase in the printed tonal range.
- c. Any focal length of lens may be used with the Cathomag without making adjustments to the system.
- d. The cold cathode grid used in the cathomag lightsource is very fragile and must be handled with great care.

9. Varicontrast Head (Code 1954)

This lightsource is specifically designed for use with variable contrast papers. A diffused tungsten lightsource that returns a high print quality similar to that of a Difcon. The fitting and connection details for this lightsource are the same as the Dichromat; fitting instructions are in Section Three and electrical connections are shown at Appendix 1 to Section Three.

10. 70mm Roll Film Drawer (Mark II) (Code 1952)

The Roll Film Drawer is supplied as a direct replacement of the standard Negative Carrier. It is basically the same sandwich type design as the standard carrier with feed and take up spools to accommodate the Roll Film. Prior to inserting the Drawer ensure that the new, longer lift pins supplied are fitted in place of the standard ones.

- a. The assembly should be loaded with the roll of film to the left and an empty take up spool on the right.
- b. Feed the film over the first guide roller, across the platten over the second roller to the take up spool, then attach it to this spool by placing into the spool slot and revolving the spool a couple of revolutions.
- c. Advance the film until the frame required has been identified then insert the drawer.
- d. Once in position, and with the lightsource operating, the frame can be aligned and masked, use the lightsource lift pin lever to raise the lightsource sufficiently for easy movement of the film.
- e. The diagram opposite shows the complete assembly removed from the enlarger.

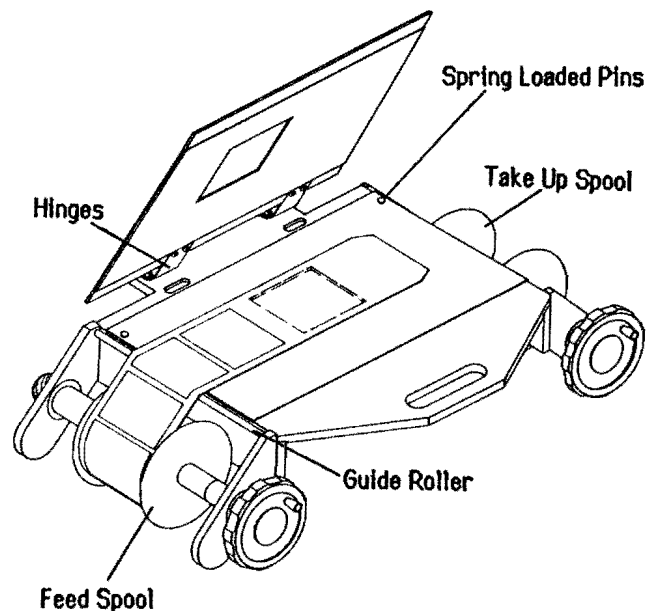


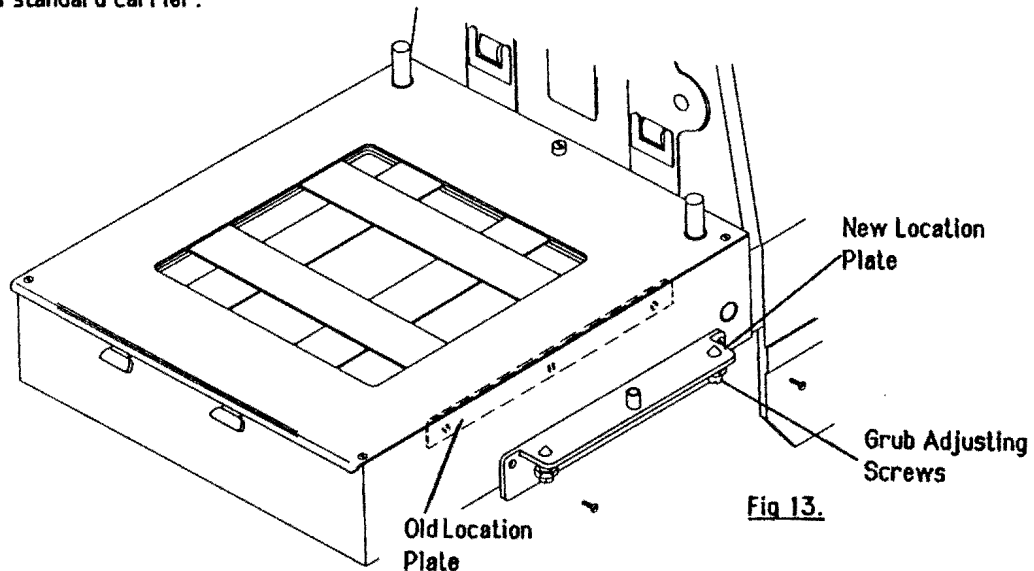
Fig 12.



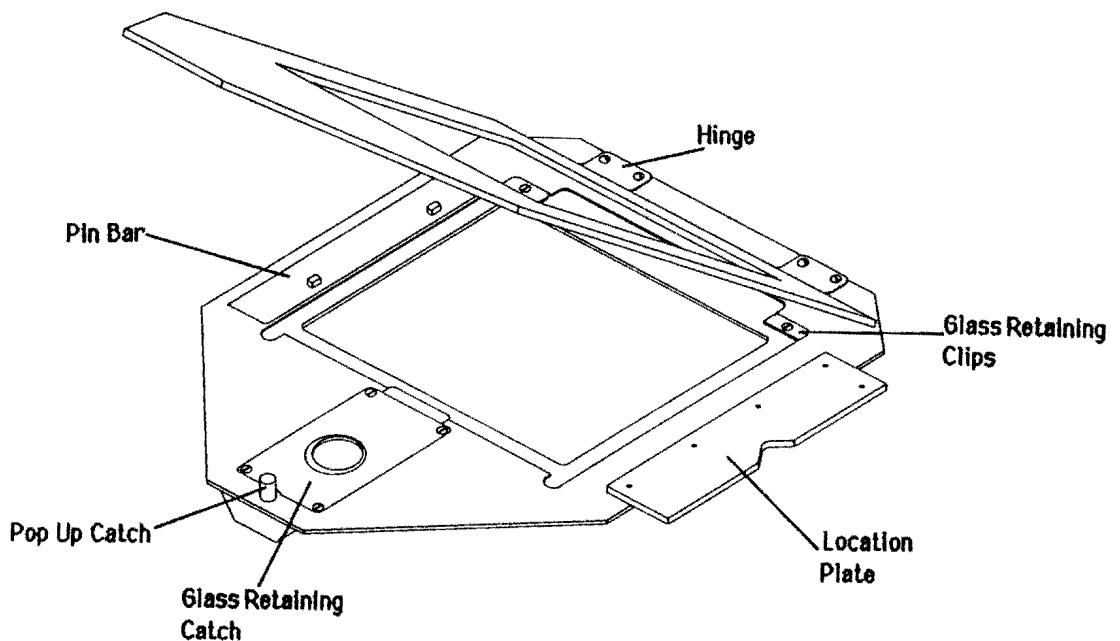
## 11. Pin Register Carrier (Code 1909)

The Pin Register Carrier is supplied as a direct replacement of the Standard Negative Carrier. The Carrier is of the same sandwich type design as the standard one but has a Kodak 4.5 Inch (114mm) Registration Pin Bar affixed to the base plate to which negatives should be attached. However, before this carrier may be used, a small modification should be carried out as follows:

- a. Affixed to the side of the Negative Stage is a small location plate secured by three screws. This plate should be removed and the replacement registration plate affixed in its place by just two screws, one at each end. See Diagram below. The removed plate must be retained for use with the standard carrier.



- b. Once the location plate has been attached to the side of the Negative Stage insert the registration carrier into the operating position - fully to the rear and fully to the right, then adjust the two pointed grub type adjusting screws on the location plate to ensure that the complete carrier will register exactly in the same position each time it is inserted.
- c. The carrier has clear glass fitted to both top and bottom sections to press flat the film once registered.



LIST OF ANCILLARY COMPONENTS

Code	Description
<u>Chassis</u>	
1980	DVB 504 Mk II Bench Enlarger
1981	DVF 504 Mk II Freestanding Enlarger
1982	DVW 504 Mk II Wall Enlarger
1998	DVF 504 Extended Mk II Chassis
1939	Drop Table Assembly
1916	Kit to convert DVB to DVW
2624	Drop Table Support Leg
6603	Colour 500 Mk 3 c/w DVB 504 Bench Enlarger
6604	Colour 500 Mk 3 c/w DVW 504 Wall Enlarger
6605	Colour 500 Mk 3 c/w DVF 504 Freestanding Enlarger
6606	Colour 500 Mk 3 c/w DVF 504 Extended Mk II Chassis
<u>Colour Lightsources</u>	
1983	504 Dichromat Mk 4 240 Volt (1 Lamp)
1988	504 Dichromat 6cm x 7cm Light Collecting Box
1961	250 Watt Timer/Transtab 240 Volt
1955	Universal Timer 240/120 Volt
1962	250 Watt Transtab 240 Volt
1903	250 Watt Transformer 240 Volt
1748	Dichromat Lamp ELC Patt
1953	Analyser Diffuser Disc
3815	Timer Foot Switch
3893	Spare Colour 500 Mk 3 Programme Neg
3894	Spare Colour 500 Mk 3 Programme Rev
3895	Colour 500 Mk 3 Multi-Programme Neg
3896	Colour 500 Mk 3 Multi-Programme Rev
2619	500 Watt Transtab 240 Volt
1984	504 Dichromat Mk 5 500 Watt 240 Volt (2 Lamp)
1990	504 Dichromat Mk 5 6cm x 7cm Light Collecting Box
2618	500 Watt Timer/Transtab
<u>Black &amp; White Lightsources</u>	
1906	504 Varicon Less Condensers
1964	504 180mm Condenser Element
1965	504 120mm Condenser Element
1966	504 100mm Condenser Element
1944	504/507 Varicon Heat Filter 14cm Square
1522	240 Volt 150 Watt ES Enlarger Lamp
1950	504/507 Pointsource Conversion
1521	Pointsource Lamp 6 Volt 48 Watt
1905	504 Cathomag 240 Volt
1925	504 Cold Cathode Tube
1993	504 Difcon Mk 2 (240 Volt)
3847	Universal Timer Interface
1963	Swing Filter and Post
1954	Varicontrast Head 240 Volt

### Carriers

1978	504 Mk 2 Negative Carrier
1979	504 Mk 2 Negative Cups
1910	504 4in x 5in Copy Frame Mask
1911	504 9cm x 12cm Copy Frame Mask
1912	504 6cm x 9cm RollFilm Mask
1913	504 6cm x 6cm RollFilm Mask
1914	504 35mm RollFilm Mask
1915	504 Negative Glasses
1919	504 6cm x 7cm RollFilm Mask
1967	504 4.5cm x 6cm RollFilm Mask
1970	504 Anti Newton Glass
1940	504 Special Mask
1909	504 Mk 2 Pin Register Carrier
1952	504 Mk 2 70mm RollFilm Drawer
1997	504 Mk 2 Lift Pins
1953	504 Disc Carrier

### Lens Panels

1920	Series 500 Dished Panel
1921	Series 500 Flat Panel
1922	Series 500 Extra Sunken Panel
1923	504 Lens Panel Extension Tube
1971	504 Durst Panel Adaptor
1972	Panel 1920 Cut Leica Thread
1973	Panel 1921 Cut Leica Thread
1974	Panel 1921 Cut 150 Rodagon
2012	Series 500 Inverted Panel
5501	Lens Panel Cutting Charge
1977	Panel 1922 Cut Leica Thread
1985	Inverted Lens Mount

### Accessories

1907	504 Copy Back 4in x 5in
1946	Copy Light System
1948	Horizontal Projection Mirror
4701	Scoponet
1860	RE 6 RollEasel 16in x 20in } c/w Adjustable Paper
1850	RE 5 RollEasel 12in x 17in } Mask Unit
3838	RollEasel to Colour 500 Interface 240 Volt
3841	RollEasel Lamp Detect Series 500

### Note:

All numbers quoted in this Appendix are for 240V components. A converter is included in the manual to convert 240V Code Numbers into 120V Code numbers where applicable, this can be found in Section One on page 1 - 4.

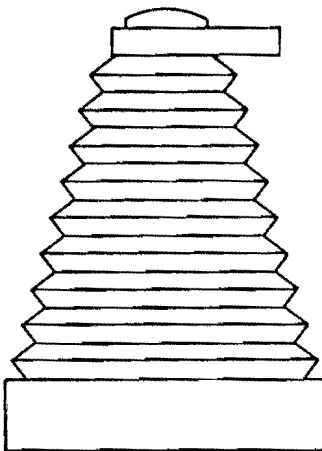
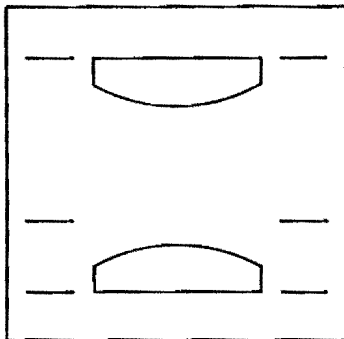
**CONDENSER ELEMENT COMBINATIONS**

**504 VARICON**

LIGHTSOURCE



CONDENSER ELEMENT  
POSITIONS WITHIN  
THE VARICON



UPPER CONDENSER	LOWER CONDENSER	LENS FOCAL LENGTH
180mm	180mm	150-105mm (5.91 - 4.13ins)
180mm	120mm	105-75mm (4.13 - 2.95ins)
120mm	100mm	60-50mm (2.36 - 1.97ins)

S - 2 - 1

Fig 15.

## SECTION SIX

### MAINTENANCE, REPLACEMENTS AND ADJUSTMENTS

1. De Vere enlargers are designed and built to give many years of trouble free service, but, to a great extent, reliability will depend upon care in the operation and cleanliness of the equipment, both of which will greatly affect the enlargement quality.

- a. General Maintenance

- (i) The equipment should be kept free of dust and dirt, all accessories, when not in use should be stowed in a clean and dry place close to the enlarger.
- (ii) Bellows should be dusted both inside and out at regular intervals.
- (iii) All running surfaces should be cleaned regularly and very occasionally a little light machine oil can be applied to the moving parts, i.e., ball races, runner tracks etc. The amount applied however, should be kept to an absolute minimum.
- (iv) All electrical connections, particularly plugs and sockets, should be examined periodically to ensure they are correctly mated and not arcing or getting warm. External cables should be checked for signs of damage to the insulation, and, if damaged, replaced.
- (v) Lenses and glass surfaces should be cleaned with clean soft and dry linen with a pure spirit solution at regular intervals. Pure spirit is recommended for this purpose but the surfaces should be thoroughly dried and polished after application. Any glass surface that is heavily coated with dust should initially be cleaned with either a camel hair or anti-static brush.

- b. Replacements

- (i) Dichromat Lamps (Code 1748)

- (a) The Dichromat Mk 4 is fitted with one 24 Volt tungsten halogen lamp reflector assembly. Before replacement of the assembly is commenced, SWITCH OFF and ISOLATE the mains power supply and allow sufficient time for the lamp assembly to cool.
- (b) Lower the enlarger head to a convenient working height and tighten both drive lock knobs.
- (c) Raise the forward top panel that is secured by a pull catch.
- (d) Pull the lamp ejector lever situated on the right hand side of the lamp towards the front of the Dichromat therefore raising the lamp from behind the retaining springs.
- (e) Ensuring the lamp is cool enough to touch lift out from the compartment and disconnect the electrical connector.
- (f) Connect the electrical lead to the new lamp assembly and replace behind the retaining clips.
- (g) Check the electrical connections then close the top panel.

- (ii) NOTE:

The Dichromat Mk 5 is, in construction and operation, the same as the Mk 4 except that it has two 24 volt tungsten halogen lamps for greater light intensity and not just the one. Replacement of these lamps is therefore the same as for the Mk 4.

(iii) Display Panel Illumination Bulb - Dichromats

In the unlikely event that this bulb requires replacing it is located under the lamp assembly mounting panel and within a Nylon retaining block. The bulb is a round (M.E.S.) 6.5 Volt 0.3 Amp and should be easily obtainable.

(iv) Varicon Lamp (Code 1522)

This is a 150 Watt tungsten lamp having an Edison Screw (ES) cap. To replace this lamp SWITCH OFF and ISOLATE the electrical supply to the enlarger and proceed as follows:

- (a) Lower the enlarger head to a convenient height and tighten both drive locking screws.
- (b) Remove the four knurled headed screws located two on each side at the bottom and lift off the lightsource housing.
- (c) Wind the lamp down to the bottom of the vertical slide using the adjusting knob on the right hand side. Unscrew the lamp from its socket and remove.
- (d) Fit new lamp, replace and secure the housing with the knurled headed screws then, if required, re-adjust the lamp as described in Section Five paragraph 5.

(v) Cathomag Tube (Code 1925)

This is a high power diffused lightsource having a special cold cathode tube which is attached to a reflector with four wires. To replace this tube SWITCH OFF and ISOLATE the mains electrical supply to the enlarger and proceed as follows:

NOTE: The cold Cathode Tube is very fragile and must be handled with extreme care.

- (a) Bring the head down to a convenient height and lighten both drive lock screws then remove the lightsource from the enlarger.
- (b) The outer casing of the lightsource is secured with four screws, two at the bottom of the front panel and two on the top at the rear. Remove these screws and lift off the casing.
- (c) The tube/reflector assembly is restrained from upward vertical movement by two brackets one at each side and each is secured by a single screw which is accessible on the outside of the inner casing. Remove these screws and brackets.
- (d) Draw the tube/reflector assembly forward and remove the front wire from the connection on the tube. The connecting loop can be expanded for easy removal by pressing on the free end of the loop. Draw the assembly forward and remove the other wire from the tube in the same manner.
- (e) Fit the new tube to the reflector and secure with the wires. Re-assemble the lightsource in the reverse order to that stated above and re-fit to the enlarger.

(vi) Drive Cable Replacement - DVB & DVW Models

The DVB & DVW Models have cable driven Lens and Negative Stages which very occasionally may require replacement. The diagram opposite shows the cable routing and securing points within the column for the DVB & DVW Models. The method of changing cables is the same on both sides of the column except that the cables are wound in a reverse direction as explained in sub-paragraph (k) below. All instructions are therefore the same for both Lens and Negative Stage cables unless otherwise specified.

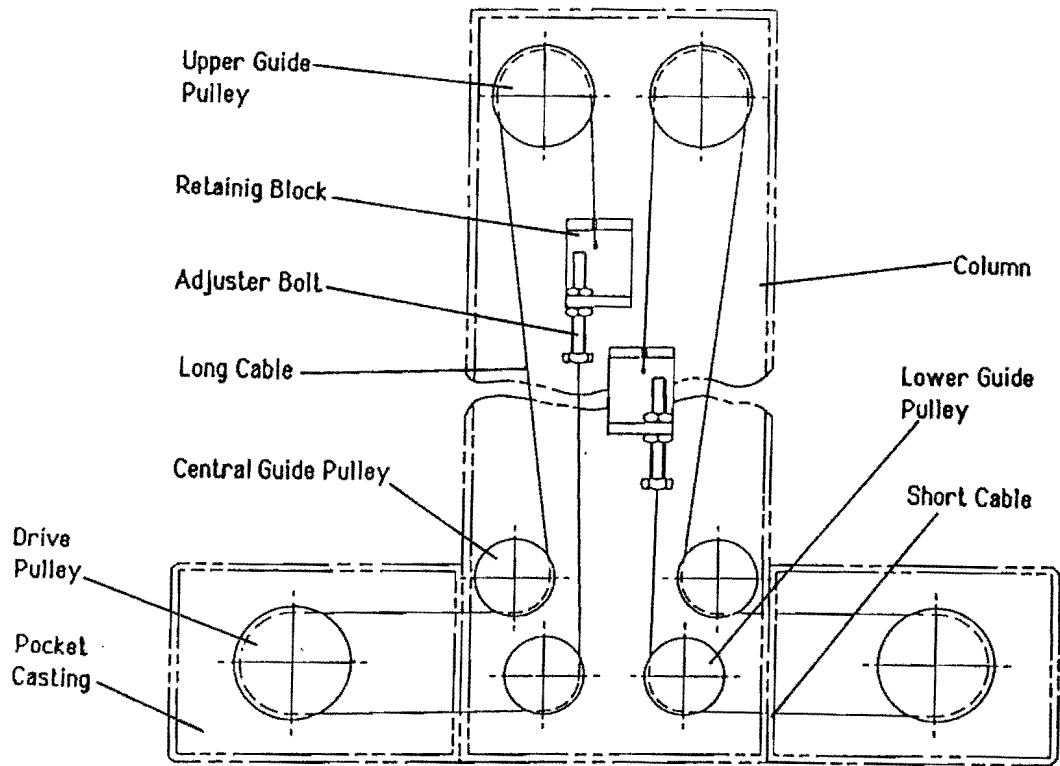


Fig 16.

- (a) Lock the Lens and Negative Stages at a convenient height on the column.
- (b) Position the enlarger so that all round access can be gained then remove the rear inspection panels from the column.
- (c) Remove the handwheel for whichever stage is to be worked on by releasing the centrally captive bolt at the rear.
- (d) Remove the rear section of the pocket casting by releasing the three captive screws recessed within the rear casting.
- (e) Normally, the cable will require replacement because of a breakage, so all pieces of cable should be removed from with the column. If not replacing for this reason, reduce the tension on the cable by releasing the adjuster bolt and retaining nut.
- (f) Remove the Drive Pulley from the pocket casting and release the two grub screws retaining the cables to the pulley then remove any cable pieces from the drum and pocket casting.
- (g) Commence assembly by threading the shorter of the two cables through the centre of the adjuster screw from the threaded end.
- (h) Identify the narrower of the two internal dimensions of the central pulley spindle as shown in the diagram overleaf and hold that end with thumb and fore finger with the wider of the two ends facing you.

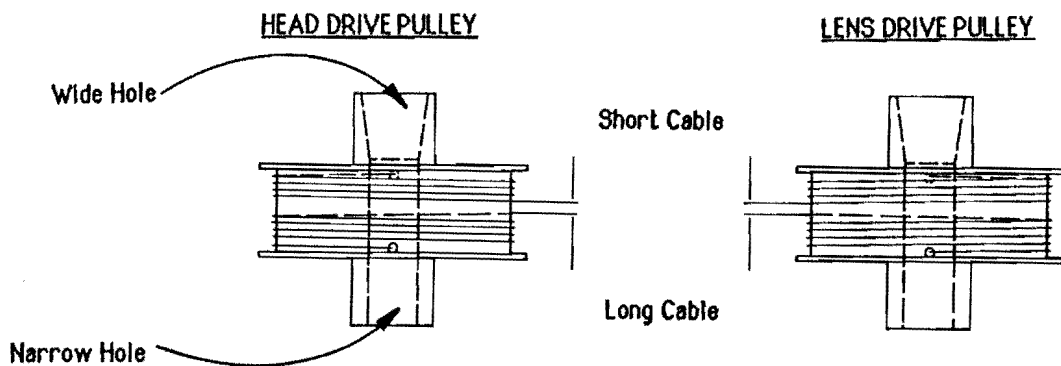


Fig 17.

- (j) Now take the other end of the short cable and feed into the small hole on the pulley furthest away from you then take the long cable and feed into the hole on the opposite side of the Pulley - i.e., nearest to you. Secure both cables with the grub screws previously removed and ensure they are firmly fastened.
- (k) Still holding the pulley in the same way, in the left hand looking at the tapered end, take the short cable and wind onto the pulley three and a half times in a clockwise direction (See Note One below), hold with the right hand and then take the long cable in the left hand and wind onto the pulley four and half times in an anti-clockwise direction (See Note Two below), then hold both cables securely with thumb and fore finger.

Note One: Clockwise for Head Drive Pulley, anti-clockwise for Lens Drive Pulley.

Note Two: Anti-clockwise for Head Drive Pulley, clockwise for Lens Drive Pulley.

- (l) Position the Pulley into the pocket casting, and with the help of another person to hold the cables securely on the pulley, feed the long cable through the hole in the side of the column casting, under the centre guide pulley and up to the top of the column, over the upper guide pulley, then down to the adjuster block and insert the nipple, on the end of the cable, into the slot provided.
- (m) Take the short cable with the adjuster and feed through the lower hole in the side of the column casting, under the lower guide pulley and up to the adjuster block. Feed the adjuster into the hole provided and secure with the lock nut.
- (n) Replace the rear section of the pocket casting and secure with the three screws and then replace the handwheel.
- (o) Adjust the tension of the cable as per instructions in sub-paragraph (ii) on page 6 - 6 and replace the rear inspection panels on the column.

(vi) Drive Cable Replacement - DVF & DVF Extended

Replacing the two Drive Cables fitted to the DVF and DVF Extended Models is similar to that of the DVB & DVW Models, the main differences, which are shown in the diagrams below, are:-

- (a) the cable routing within the column is reversed.
- (b) the position of the long and short cables fitted to the Head & Lens Drive Pulleys is also reversed.

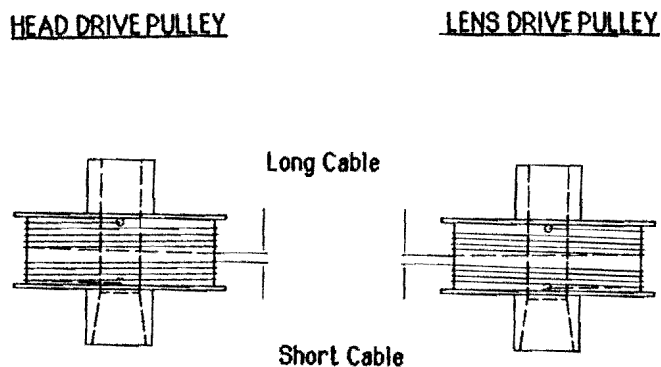
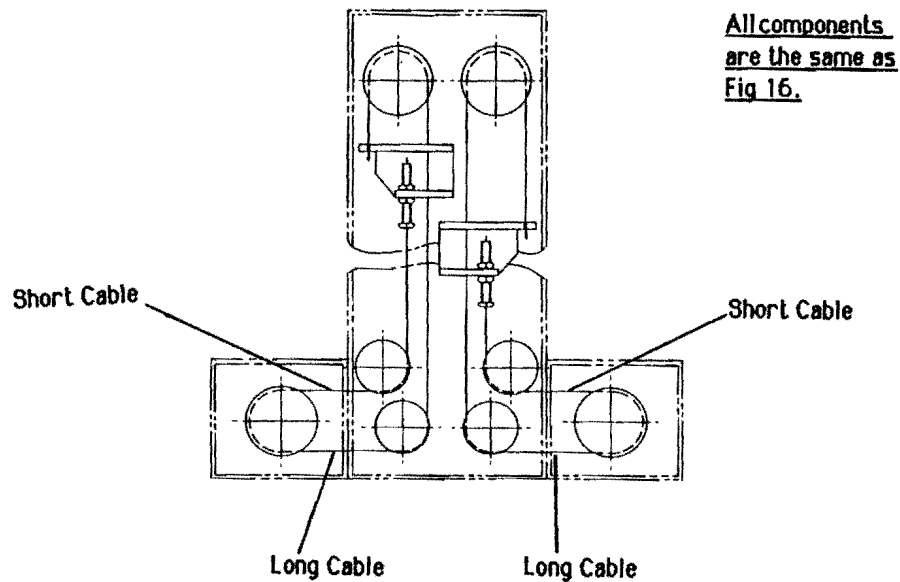


Fig 18.





All components are the same as Fig 16.

Fig 19.

(c) Complete steps (a) - (k) for the DVB & DVW Models then proceed as follows:

- (l) Position the Pulley into the pocket casting, tapered hole facing out, then with the help of another person to hold the cables securely on the pulley, feed the short cable with the adjuster through the upper hole in the side of the column casting, under the centre guide pulley and up to the adjuster block. Feed the adjuster into the hole provided and secure with the lock nut.
- (m) Take the long cable and feed through the lower hole in the column casting, under the lower guide pulley and up to the top of the column passing through the adjuster block, over the upper guide pulley, then down to the adjuster block and insert the nipple, on the end of the cable, into the slot provided.
- (n) Replace the rear section of the pocket casting and secure with the three screws and then replace the handwheel.
- (o) Adjust the tension of the cable as per instructions in sub-paragraph (ii) on page 6 - 6 and replace the rear inspection panels on the column.

c. Adjustments

(i) Head Support Plate Nylon Tension Rollers

(a) The Head Support Plate contains four Nylon Tension Rollers only the two lower ones of which, on all current models, require adjusting. The upper two are retained for use with earlier type lightsources that had different methods of attachment.

(b) With the lightsource in an operating position and with the tension spring attached, adjust the lower rollers with the two grub screws located one on each side as shown in the diagram opposite. Adjustment should be made with the 1/16th AllenKey provided.

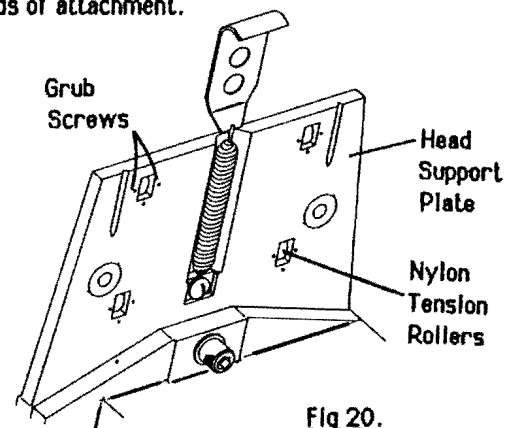


Fig 20.

- (c) With the lift pins in the lowered position adjust the grub screws until the space between the light source and the negative stage carrier (measurement (a)) is the same both front and rear as shown in the diagram below. Very little adjustment will be required to effect a change.

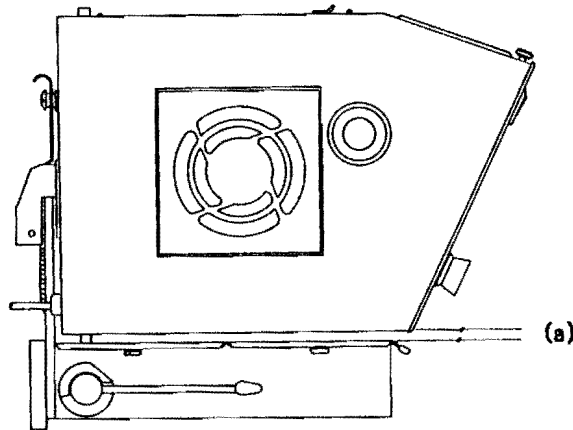


Fig 21.

(II) Drive Cable Tension

Both the Negative and Lens stage runners are driven by cables that transfer the movement from the handwheels via pulleys that are Intern tensioned by counter-balance springs (tensators). These cables are tensioned during manufacture of the enlarger and it is unlikely they will require attention for some time. Any slippage between the movement of the handwheels and the movement of the runner assemblies however, will indicate that adjustment is required. If so, proceed as follows:

- (a) Detach the DVW Model from the wall, or position either the DVB or DVF (Extended) models so that access may be gained to the rear of the column.
- (b) Remove the central inspection cover secured by two screws on the rear face of the column and then adjust the position of both the negative and lens stage runners until both cable adjusting brackets appear in the inspection aperture.
- (c) The arrangement and method of adjustment is exactly the same for both cables, one end is anchored to the adjusting bracket while the other end passes through the bracket and is then attached to a hollow screw which is in turn secured by two nuts. Slacken the other (bottom) nut and then, holding the head of the screw, tighten the other nut until the slack in the cable has been taken up and the slippage of the handwheels has ceased.
- (d) Do not overstrain the cables but allow approximately 1/2 - 1 inch total of side to side movement. Tighten the outside nut to lock the screw into the bracket then replace and secure the inspection cover.

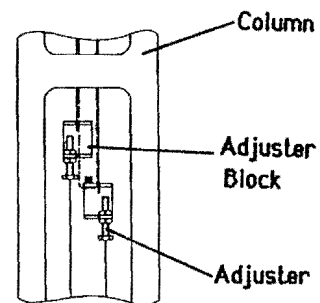


Fig 22.

### (iii) Drop Table Drive Chains (DVF Model Only)

The two Drop Table drive chains are contained within the drop table assembly, one on each side. Access to the chains is gained by removing the two covers at the rear of the assembly. The chains are correctly tensioned during manufacture and it is most unlikely that they will require any attention whatsoever. If however it becomes necessary, proceed as follows:

- (a) The rear covers referred to above are each in two sections, only the small top section need be removed to check the tension of the chain. This is secured with just four screws. To take this cover away it will be necessary however, to slacken the upper screw retaining the lower section of each chain cover which also acts as a clamp for the top section.
- (b) Once this section has been removed it will be seen that the chain passes over an aluminium boss which is secured by a screw on the front face through an elongated hole and by a screw which passes through the side of the casing at the rear and into the periphery of the boss. This screw has two lock nuts but these should not be released. To adjust the tension ease the screw on the front face of the drop table assembly and turn the screw through the side of the casing in a clockwise direction until the excess slack in the chain is taken up then tighten the screw on the front face. DO NOT over adjust the tension of the chain, or a smooth movement will not be achieved, but leave approximately 1/2 inch (12mm) or slack.
- (c) Should the amount of adjustment provided by the elongated hole in the front face be insufficient to take up the slack in the chain, the aluminium boss has a second tapped hole which should be used and by removing the screw on the front face and inserting into this hole the effective range of adjustment will be increased.

### (iv) Lens and Negative Stage Tilt Mechanisms (All Models)

Both the Lens and Negative Stage Tilt arrangements have metal click stops to ensure a full return to their normal operating position after being tilted. They both operate on the same principle, consisting of a spring loaded plunger in the stage casting which operates against a steel insert in the runner casting. Each insert has a groove and the normal operating position is determined when the plunger is located into this groove. The steel inserts are located in their correct positions by socket headed screws in both the top and bottom edges of the runner castings. They are factory adjusted and it is therefore unlikely that they will require attention. However, should this become necessary, adjustment should be carried out as follows:

- (a) With the tilt arrangements in their normal operating positions and using a spirit level, check the relative attitudes of both the lens and negative stages with the baseboard. All three readings should be the same.
- (b) If not, determine from the readings whether the particular insert requires to be raised or lowered for correction, then release the tilt locking lever of the stage to be adjusted.
- (c) Adjust the position of the insert by easing either the top or bottom screw as necessary and tightening the other. Repeat the adjustments until both the negative and lens stages are level in relation to the baseboard. Ensure the locating screws are fully tightened after each adjustment to prevent the insert moving, therefore giving a false spirit level reading.

### (v) Tensioning of Negative and Lens Stage Handwheels (All Models)

Should the tension on either of the handwheel controls become loose, adjustment can be made by means of the nylon screws located at the rear of the enlarger, directly behind the drive lock knobs. To adjust, tighten the nylon screw to the desired setting. The method of adjustment is the same for both of the handwheels.

(vi) Lens Panel Retaining Bosses (All Models)

Each lens panel has two cut outs located opposite each other on the edge of the panel which, when located behind the two plastic covered bosses, within the lens runner assembly, retains the panel in the operating position. These plastic covered bosses are factory adjusted to ensure the panel is firmly held in position, therefore, only after considerable use will adjustment be required. When the lens panel becomes loose, adjust as follows:

- (a) Remove the lens panel and lower the negative and lens stages to their lowest position so that the bellows are fully compressed. Tighten both the negative and lens stage locking levers securely.
- (b) Disconnect the tension spring and lift off the lightsource then fully open the four-way masking blades.
- (c) The plastic bosses are permanently attached to one end of a flat spring and retained in position by just one screw.
- (d) Remove the screws and withdraw the spring, then slightly reduce the angle of each of the springs by carefully bending in the direction indicated in the diagram opposite.
- (e) Replace and secure the assemblies into position, check the fit of the lens panel, and if necessary repeat until the panel is held firmly.

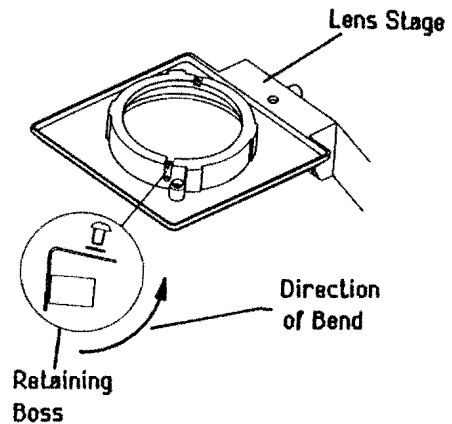


Fig 23.

# SPARE PARTS LISTS

## 504 ENLARGLR AND ACCESSORIES

A	B	C	Code No	Description	Comments
				<u>Chassis</u>	
		x	B0651	AllenKey 1/16 AF	
		x	B0652	AllenKey 3/32 AF	
		x	B0653	AllenKey 3/16 AF	
		x	B0654	AllenKey 7/32 AF	
		x	D5126	Nameplate	
	x		D3106-1	Bellows	
	x		SA3105	Vee Roller Assy	
	x		SA3104	Headrunner Assy	
x	x		SA3116A	Tensator Assy	
x	x		SA3123-1	Top Cable Long 95 1/2 ins	
x	x		SA3123-2	Bottom Cable 50 1/4 ins	(DVB & DVW)
x	x		SA4042	Bottom Cable 51 3/4 ins	wef 10/84 (DVF)
		x	CP021	Screw Set	
		x	D3100A	Runner Guide	
		x	D3122A	Cable Connector	
		x	D3122B	Cable Adjuster	
x	x		B0287	Black Knob 44mm	
	x		D5128	Imperial Scale	
	x		D5129	Metric Scale	
	x		CP008	DVB Baseboard	
	x		CP010	PulleyLockscrew	
x	x		B0416A	Lens Tensator SR14	
	x		SA3132	Cam Assy	
x	x		SA3138	Spring Clip Assy (Lens Panel)	
	x		B0559	Kipp Handle (Lens)	
	x		B0560	Kipp Handle (Head)	
	x		SA3124	Hand Control	(DVB)
	x		SA3124A	Hand Control	(DVW)
	x		D0986	Base Adjusting Screw	
	x		AK2BA1000	Baseboard Screw (3)	
	x		SA4057	DVF Table Tensator Assy	
				<u>Negative Carrier</u>	
x	x		D2278-1	Hinge	
	x		D4065	Mask Clip	

			<u>Dichromat Mk 4 &amp; Mk 5</u>		
		x	B0561	Dial Light Transformer	
		x	D4244	Dial Knob	
	x		B0582	Filter 1 in Sq Yellow	
	x		B0582A	Filter 1 in Sq Magenta	
	x		B0582B	Filter 1 in Sq Cyan	
	x		CP014	Set of Matched Filters	Mk 5 Head
		x	B0201	8 Pin Plug	
		x	B0593	Small Axial Fan (240V) } Pre Jul 84	
		x	B0593A	Small Axial Fan (120V) } Pre Jul 84	(1991 & 1992)
		x	B0617	5 Core Cable (6.5ft)	
	x		B0813	GE11 Lampholder	
x	x		B0814	GCX5 Lamp Connector	
	x		B0609	Fibre Optic	
	x		B1147	Panel Light Switch	
x	x		D6442C	Small Axial Fan (240V) } Wef Jul 84	
x	x		D6442D	Small Axial Fan (120V) } Wef Jul 84	(1991 & 1992)
	x		B1140	Grommet 1/4P Hole 4mm ID } Wef Jul 84	
	x		B0571B	Oddie Washer 726 } Wef Jul 84	
	x		B1193	Bulb 6.5V 0.3A M.E.S.	
			<u>Difcon</u>		
	x		B0593	Small Axial Fan (240V) } Pre Jul 84	
	x		B0593A	Small Axial Fan (120V) } Pre Jul 84	(1994)
		x	D3233	Drawer Handle	
	x		B0201	8 Pin Plug	
	x		B0813	GE11 Lampholder	
x	x		B0814	GCX5 Lamp Connector	
		x	D6228	Solenoid P.C.B.	
x	x		D6442C	Small Axial Fan (240V) } Wef Jul 84	
x	x		D6442D	Small Axial Fan (120V) } Wef Jul 84	
	x		B0571B	Oddie Washer 726 } Wef Jul 84	
	x		B1140	Grommet 1/4P Hole 4mm ID } Wef Jul 84	
			<u>Cathomag</u>		
	x		D1199B	Cold Cathomag Tube Clip	
	x		D3254	Diffuser Opal	
		x	B0385B	Nameplate	
	x		B0793A	1/2 x 1/8 Ins Adhesive Rubber	
	x		CP036	Cold Cathode Tube & Reflector	
	x		B0159A	Transformer	
	x		D2240A	Thumbscrews	
			<u>Copyback</u>		
	x		CP012	Clamp Assy	
x	x		D0764-R	4 x 5ins Ruled Ground Glass Screen	
x	x		D0887B	Glass Clip	
	x		CP011	Counterbalance weight	
	x		D3246A	Mirror	
	x		D3246B	Mirror Clips	

				<u>Varicon</u>	
x	x		D1508	Top & Bottom Pulley	
	x		D3233	Drawer Handle	
x	x		SA3527	Drive Wire	
	x		B0020C	Lampholder 3mm Thread Brass	
		x	B0385A	Name Plate	
x	x		B0441B	Magnetic Catch	
x	x		B0484	150 Watt Enlarger Bulb	
	x		B0363D	Knob	
	x		B0668	Condenser Varicon Chart	
	x		B0079C	12 Way Terminal Block	
				<u>Varicon Pointsource Conversion</u>	
	x		B0020C	Lampholder 3mm Thread Brass	
	x		B0363	Rheostat Rotary 400W	
	x		B0363D	Knob	
	x		B0417B	6V 48W Lamp	
	x		B0643	Fuse 5 Amp 20mm	
	x		D3522	Spring Clip	

**CLASSIFICATION:** A - Recommended to be bought by user where no Agent back up in Country.  
 B - Recommended to be held by Agent.  
 C - Available if required.

Fitting instructions are available if required.